

# *Flow Line 70/71*

*Wafer & Lug Style  
Sizes 14" - 24"*

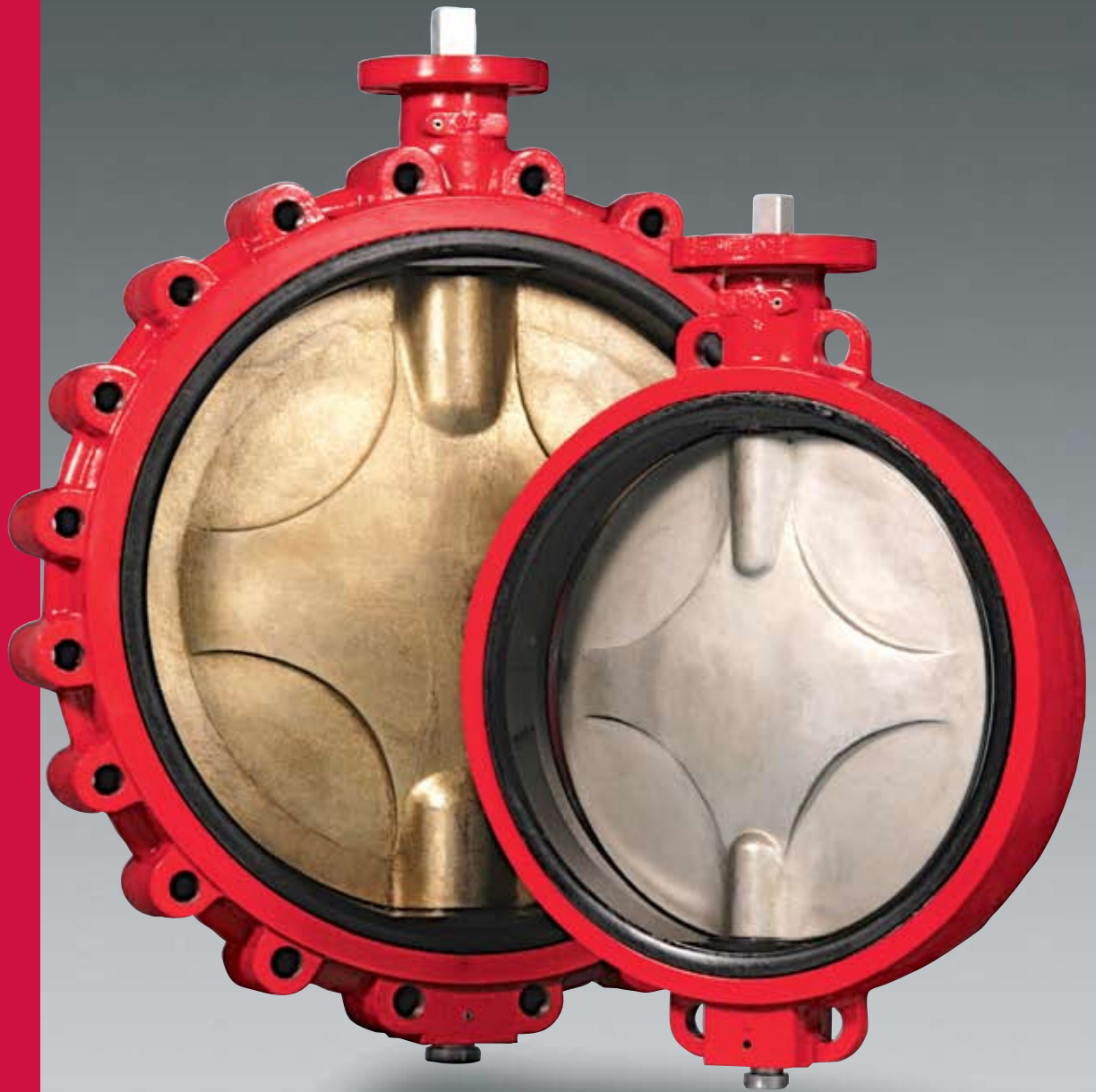

**Flow Line**  
Valve and Controls

**Cartridge Seated  
Butterfly Valves**

# KEY FEATURES

## Body

- One piece wafer and lugged body is Polyester coated as standard for a superior appearance and excellent resistance to external corrosion.
- Heavy duty ISO 5211 Top plate is slotted for ease of actuation and engineered to accept direct mounting of operators.
- Standard extended neck provides full clearance for 2" of insulation.

## Disc

- Streamlined design offers higher Cv and lower pressure drop.

## Shaft

- Triple shaft seals support the primary seal on machined radius of the disc. Our triple shaft seals ensure a dry stem design.
- Two secondary shaft seals are located inside the seat shaft holes and an environmental shaft seal eliminates contaminants from entering the shaft bore.
- Two self lubricated bronze bearings offer consistent torque value and eliminate side loading.
- ISO 5211 shaft standard for ease of automation.

## Disc/Shaft Connection

- A high strength, Double D drive ensures a positive shaft to disc connection.
- Disc floats inside the seat for positive sealing and extended seat life.
- No pins or bolts are exposed to flow.
- Offset shaft retainers mechanically retain the shaft in the body ensuring a blow out proof design.

## Shaft Sealing Method

- Disc shaft holes surrounded by a 360° machined radius are in constant contact with the flatted area of the seat.
- This design is far superior to resilient flexible seat designs that depend on the "squeeze" effect of the disc and seat interference which allows leakage behind the seat and up the shaft.
- The Flow Line shaft seal is achieved through a continuous pressure exerted from the flatted area of the seat to the machined radius of the disc.
- This sealing mechanism is further enhanced by forces exerted on the seat and shaft providing a secondary seal resulting in media free disc, shaft and seat connection.

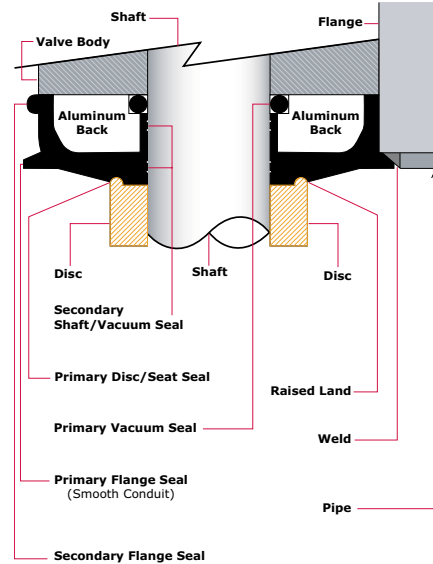

## Seat and Flange

- Field replaceable, aluminum seat back is vulcanized to elastomer seat face forming a cartridge seat that provides no movement. Elastomer/seat migration downstream of line pressure is a common failure point of many resilient flexible seat designs.
- Torque fluctuation is eliminated by our aluminum vulcanized elastomer seats.
- Our dual purpose primary flange seal is widened offering additional compression of the elastomer against various flanges resulting in a positive seal.
- This resulting primary flange seal provides a smooth flow conduit for media and prevents build up in crevices created by traditional seat designs.
- Molded secondary flange seals assure no leakage when used with weld neck, slip on and threaded flanges and eliminates the need for gaskets or O-rings.
- Aluminum backed cartridge seat design allows for dead end of service.

## Applicable Standards

- ANSI B16.1 Conforms to ANSI Class 125 flange drilling.
- ANSI B16.5 Conforms to ANSI 150 flange drilling.
- ANSI B16.42 Conforms to ANSI Class 150 flange drilling, body wall thickness and pressure-temperature ratings.
- ANSI B16.104 Exceeds Class VI shutoff requirements.
- API 609 Butterfly Valve Category A.
- AWWA C504 Diameter of stainless steel shaft exceeds AWWA Class 75B standard. Body wall thickness exceeds the AWWA Class 150B standard for butterfly valves.
- MSS SP-25 Markings and identification conform to the requirements.
- MSS SP-67 Butterfly Valves
- ISO 5211 Actuator Mounting
- USCG Category "A" Title 46, CFR, Part 56
- ABS American Bureau of Shipping

## DIMENSIONS

N BOLT CIRCLE  
M STUD SIZE  
L No STUDS

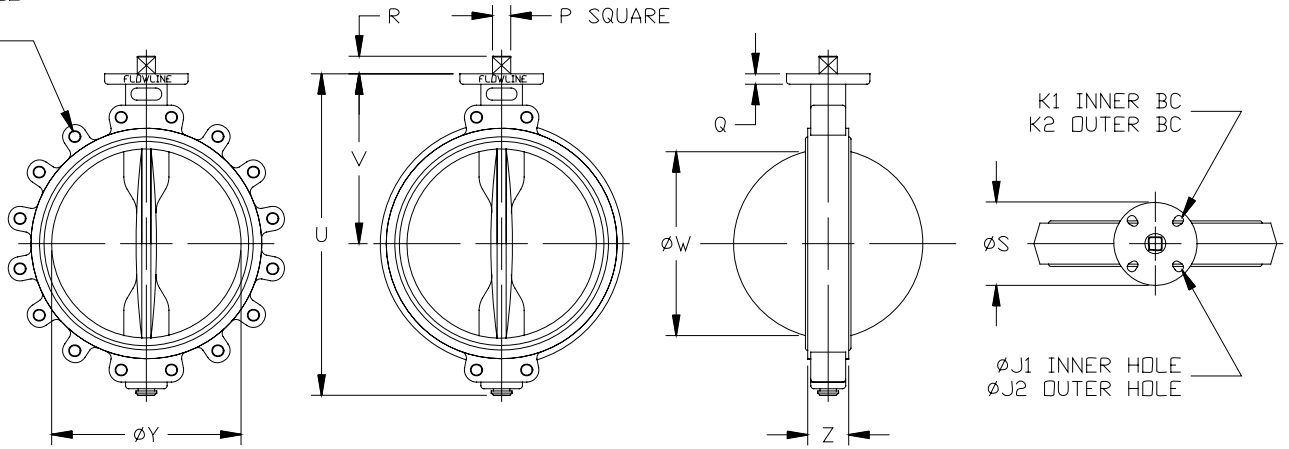

Valve Size	Z	Y	W	V	U	S	R	Q	P	Lug Drilling			Top Plate Drilling				Weight (lb)	
										N	M	L	K1	K2	#holes	J1		J2
14	2.87	13.12	12.62	13.04	23.18	6.87	1.45	.86	1.06	18.75	1-8 UNC	4	4.92	5.51	4	.625	.75	120
16	3.37	15.62	14.39	14.01	26.52	6.87	1.45	.86	1.06	21.25	1-8 UNC	4	4.92	5.51	4	.625	.75	165
18	4.18	17.56	16.41	15.03	28.18	6.87	1.45	.98	1.06	22.75	1-1/8-7 UNC	4	4.92	5.51	4	.625	.75	210
20	5.18	19.56	18.67	16.06	30.25	6.87	1.92	.98	1.41	25.00	1-1/8-7 UNC	4	-	5.51	4	.625	.75	250
24	6.02	23.56	22.84	19.12	35.87	6.87	1.92	.98	1.41	29.50	1-1/4-7 UNC	4	-	5.51	4	-	.75	400

## CLASS II TORQUES (Inch-Pounds)

Shutoff Pressure	14	16	18	20	24
50 PSI SHUTOFF	4063	5397	6275	7950	14700
75 PSI SHUTOFF	5099	6772	8301	10277	19765
100 PSI SHUTOFF	5367	7129	8738	10819	20805
125 PSI SHUTOFF	5650	7504	9198	11388	21901
150 PSI SHUTOFF	5765	7658	9386	11620	22384
175 PSI SHUTOFF	6478	8604	10546	13057	25110
200 PSI SHUTOFF	7198	9560	11718	14508	27900
250 PSI SHUTOFF	9714	12918	16275	19623	37200
285 PSI SHUTOFF	12230	16275	19995	24738	46500

### Class II

- ▲ Valve to be operated a minimum of once a month.
- ▲ Temperature well within resilient seat limits.
- ▲ Line media is a self lubricating. (Aqueous liquids)
- ▲ Minor chemical attacks on seat.
- ▲ Disc corrosion and media deposits to be mild.

## Cv VALUES

Valve Size	10°	20°	30°	40°	50°	60°	70°	80°	90°
14	358	715	908	1650	2530	3850	6820	10670	11550
16	440	880	1100	2035	3190	5060	8250	11660	14850
18	605	1210	1540	2695	4180	5500	10670	15235	19800
20	770	1540	1815	3355	5280	8140	13750	19525	25300
24	1100	2200	2640	4620	7260	11550	18700	25300	36108

### Notes:

1. This chart to be used as a guide only.
2. These torque ratings do not apply to every possible service criteria, which may affect seating and unseating torque.
3. Torque values are applicable to Flow Line Series 70/71.
4. Do not apply a safety factor to the above torque values when sizing actuators.
5. Dynamic Torque should always be a consideration when sizing valves with high differential pressures.
6. For 3 way tee assemblies multiply the above torques by 1.5.

# SPECIFICATIONS

## HOW TO ORDER

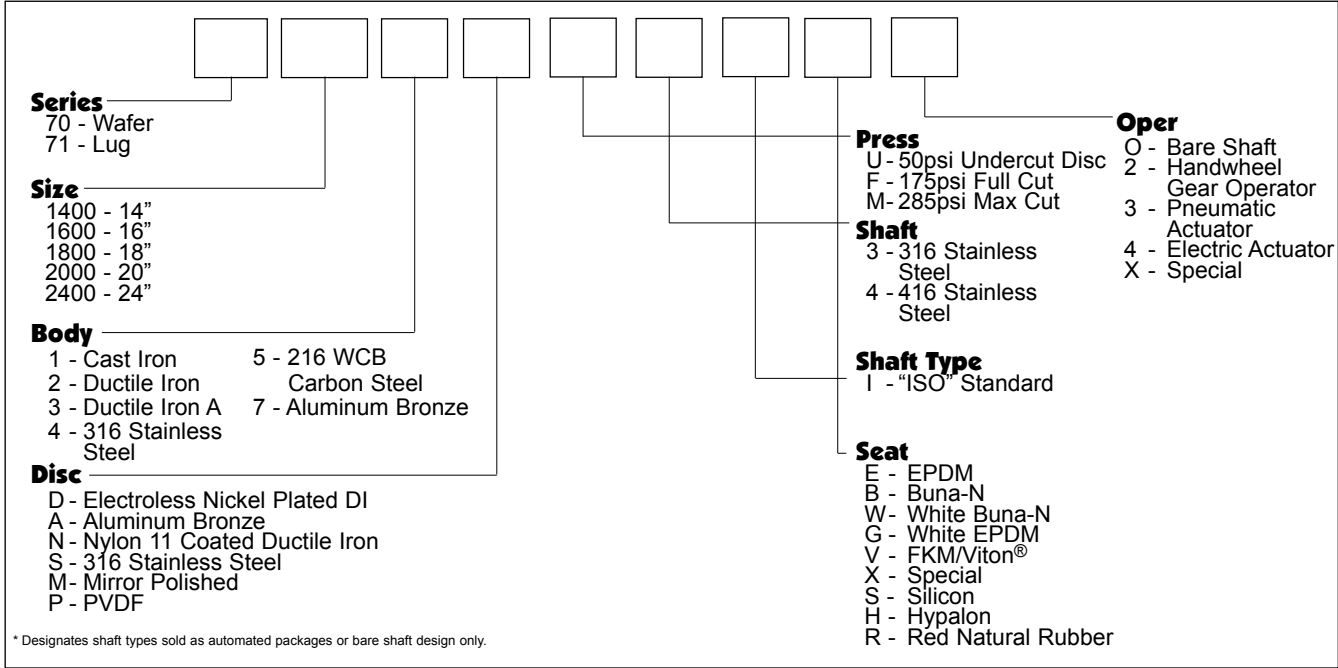

## Recommended Specifications

- Polyester coated wafer or lug bodies to provided extended necks for insulation and be able to install between ANSI 125/150 flanges. Lug design in sizes 14-24" to be fully rated for dead end service without any modification.
- Streamlined disc design with no pins or screws in the flow path and designed for high Cv and lower pressure drop.
- Upper and lower shaft design to utilize triple shaft seals as standard.
- Blow out proof design utilizing a Double D drive for a positive disc/shaft connection.
- Pressure responsive 360° sealing design will use constant pressure between machined radius on disc and flatted area of the seat.
- Valve to be Flow Line Series 70 wafer or Flow Line Series 71 lug design.

### Components

Qty	Description	Qty	Description
1	Body	2	Shaft Retainers
1	Disc	1	Bearing Retainer
1	Upper Shaft	1	Environmental Shaft Seal
1	Lower Shaft	2	Secondary Shaft Seals
1	Seat	1	Thrust Bearing
		1	Inboard Bearing

## Materials of Construction 14" - 24"

### Body

- Cast Iron ASTM A-126 Class B
- Ductile Iron ASTM A-536 (65-45-12)
- Ductile Iron ASTM A-395 (60-40-18)
- 316 Stainless Steel ASTM A-351 (CF8M)
- Carbon Steel 216 WCB ASTM
- Aluminum Bronze ASTM B-148 (954)

### Disc

- Electroless Nickel Plated Ductile Iron ASTM A-536 (65-45-12)
- Aluminum Bronze ASTM B-148 (954)
- Nylon 11 Coated Ductile Iron ASTM A-536 Grade (65-45-12)
- 316 Stainless Steel ASTM A-351 (CF8M)

### Stem

- 316 Stainless Steel ASTM A-276 Type 316
- 416 Stainless Steel ASTM A-582 Type 416

### Seat

- EPDM - FDA Food Grade -30° to +275°
- Buna-N - FDA Food Grade 0° to +180°
- White Buna-N - FDA Food Grade 0° to +180°
- Viton® - FDA Food Grade 0° to +375°
- Silicon - FDA Food Grade -80° to +450°
- Hypalon - 0° to + 180°
- Red Natural Rubber - 0° to +150°

Viton® is a registered trademark of the E.I. DuPont De Nemours Company.  
FKM is the ASTM D1418 designation for Fluorinated Hydrocarbon elastomers such as Viton® (DuPont) and Fluorel® (3M).

# FEATURES

- 
- **ISO 5211 for ease of actuation**
  - **Slotted ISO 5211 top plate for flexibility of direct mounting options**
  - **Environmental shaft seal to keep contaminants from entering shaft bore**
  - **Offset shaft retainers mechanically retain the shaft ensuring a blow out proof design**
  - **One piece Polyester coated body with extended neck**
  - **Streamlined disc with no pins or screws in flow path**
  - **Primary seal provides a smooth flow conduit and prevents media buildup in crevices normally found with traditional designs**
  - **High strength upper and lower shafts with triple shaft seals**
  - **Two self lubricated bronze bearings to eliminate side loading**
  - **Double D Drive for a positive disc/shaft connection with no pins or bolts exposed to flow**
  - **Proven pressure responsive 360° sealing method uses constant pressure between machined radius on disc and flatted area of the seat that eliminates the “squeeze” of the interference seat design our competition relies on**
  - **Aluminum Vulcanized cartridge seat with primary and secondary seals provide no movement of elastomer**
  - **Two secondary shaft seals located inside the seat shaft holes**

The **Series 70 wafer** style and **Series 71 lug** style are heavy duty cartridge seated butterfly valves compatible to ANSI 125/150 weld neck, slip on and threaded flange standards. 14”-24” valves are fully rated to 175 psi bi-directional, dead end service. Valves with undercut discs to 50 psi are also available through the size range. Valves with Max cut Disc to 285 psi are also available through size range. All Series 70/71 valves, regardless of the rated working pressure, are vacuum rated to 29.92” of Mercury Gauge (0 micron).

## COATINGS

Flow Line Series 70 and 71 butterfly valves bodies are Polyester coated as standard. Polyester is a significant upgrade to paint or two part epoxy coatings. Our standard Polyester coating offers outstanding protection against abrasion and corrosion. The Flow Line Polyester coating is not affected by outdoor exposure and maintains excellent resistance to UV rays.

TEST	RESULT
Salty Fog Test	No change in excess of 2000 hours
Outdoor Weathering (UV Rays)	No noticeable change in excess of 12 months
50% Sulfuric Acid Test	No change for 48 hours

# INSTALLATION, MAINTENANCE AND ASSEMBLY

## Flow Line Series 70 / 71

The Flow Line Series 70 / 71 top mounting flange and shaft fully conforms to ISO 5211. This allows for direct mounting of all of Flow Line's gear operators, pneumatic actuators, and electric actuators through out the full size range

### Actuation



Series 21 spring return actuators are available throughout the size range.



Series 50 solenoid valves are available in 1/8", 1/4", and 1/2"NPT.



Series 52 and 53 limit switches provide local and remote valve position.



Series 55 and 56 positioners are available with either a 3-15 psi or 4-20 MADC signal.

### Installation

To install, simply close the valve, position between the flanges and assemble the valve to the flanges with studs or cap screws. Do not use flange gaskets. Flow Line Series 70 and 71 butterfly valves can be installed with the disc closed. Before hand tightening the flange bolts, fully open the disc to ensure disc O.D. clearance with pipe I.D. Hand tighten the flange bolts and close the valve to check for valve disc and pipe clearance. If contact is made, reposition as necessary and tighten all flange bolts to proper torque specification.

### Maintenance and Repair

No regular maintenance or lubrication is required. Factory assembly procedures provide adequate lubrication for the life of the valve. To replace any component, remove valve from the line by fully closing valve disc. Spread flanges, remove all bolts then remove valve from line.

### Testing

All Flow Line Series 70 and 71 butterfly valves are bi-directionally tested to 130 percent of rated working pressure. Test certification is available upon request at time of order.

### Flanges

ANSI 125/150 cast iron, steel, raised face, flat faced weld neck, slip on and threaded flanges are suitable for use with Flow Line butterfly valves. Please contact the factory for proposed installation with plastic flanges.

### Warranty

All products manufactured by Flow Line Valve and Controls are warranted against defects in material and workmanship for a period of 2 years from date of installation.

All statements, technical information and recommendations in the bulletin are for general use only. Flow Line Valve and Controls is not responsible for suitability or compatibility of these products in relation to system requirements. Consult Flow Line Valve and Controls distributors or factory for the specific requirements and material selection for your intended application. Flow Line Valve and Controls reserves the right to change or modify product design or product without prior notice. Flow Line Valve and Controls is not responsible for editorial or pictorial errors within this literature.



110 Main Project Rd. Schriever, LA 70395  
Phone (985)414-6004 Fax (985)414-6072  
Toll 800-815-9226  
[www.flowlinevalves.com](http://www.flowlinevalves.com)

Doc. No. FLBVL2  
©2007 Flow Line