

**FlowLine**

*Series 72/73*



*Wafer & Lug Style*

*Sizes 1"-24"*

**Cartridge Seated Butterfly Valves**

# KEY FEATURES

## Body

- One piece wafer and lugged body for strength and stability in extreme environments.
- Wafer bodies have a heavy external rib providing a quick and accurate alignment during installation.
- Heavy duty top plate is drilled and slotted to ISO 5211 and other existing valve drillings, thus allowing ease of automation and interchangeability
- Standard extend neck provides full clearance for 2" of pipe insulation.
- Two part polyester coated body provides a tough and durable coating against corrosion.

## Disc

- All 316 stainless steel disc are polished to a mirror finish.
- Disc have a streamlined design providing higher Cv and lower pressure drop.
- The disc edge is contoured to give a tighter seal with lower torque.

## Shaft

- Oversized shafts allow for greater strength and thus more stability to the disc.
- Two self lubricated bronze bearings are machined to tolerances to the shaft and body eliminating side loading for the shaft. Thus preventing shaft leaks common to single bearing valves.
- Blowout proof design is achieved by utilizing the

## Disc/Shaft Connection

- A high strength, machined Double "D" connection ensures a positive shaft to disc connection
- Offset shaft retainers will not permit the shafts from moving up and down, thus preventing jamming of the disc into the seat.

## Shaft Sealing Method

- PTFE and elastomer are both vulcanized to a rigid phenolic ring. This cartridge seat provides a stable platform, eliminating movement of the PTFE and elastomer.
- Torque fluctuation is eliminated because of the constant conformity of the seat provided for by the cartridge design.
- Large flange seal area assures no leakage when used with lined or unlined flange mating services. There is no need for gaskets or o-rings.
- Cartridge design allows for full field replacement.

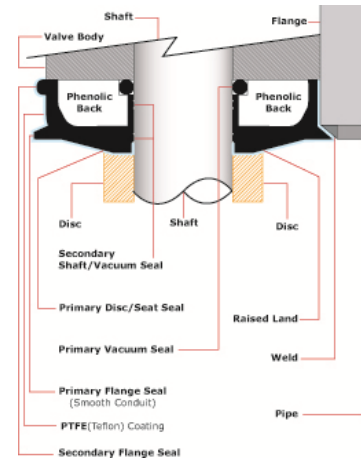

## Seat/Disk/Shaft Sealing Method

- The Flow Line shaft seal is achieved through a continuous pressure exerted from the flattened area of the seat to the machined flattened area of the disc.
- The raised flattened area of the seat corresponds precisely with the machined flattened hub area of the disc. These matching flattened surfaces provide a wide sealing area for the elastomer backed PTFE seat to exert pressure against, forming the primary seal.
- Secondary sealing is provided by a 360° machined radius on the flattened hub.
- This sealing mechanism is further enhanced by forces exerted on the seat to the 360° radius on the disc providing a secondary shaft seal.
- Both seals are made without the shaft ever coming in contact with the line media.
- Elastomer seals are utilized to further assure no leakage to the outside environment. The seals are two molded in o-rings in the shaft bore area of the seat.

## Applicable Standards

- ANSI B16.1 Conforms to ANSI Class 125 flange drilling.
- ANSI B16.5 Conforms to ANSI 150 flange drilling.
- ANSI B16.42 Conforms to ANSI Class 150 flange drilling, body wall thickness and pressure-temperature ratings.
- ANSI B16.104 Exceeds Class IV shutoff requirements.
- API 609 Butterfly Valve Category A.
- AWWA C504 Diameter of stainless steel shaft exceeds AWWA Class 75B standard. Body wall thickness exceeds the AWWA Class 150B standard for butterfly valves.
- MSS SP-25 Markings and identification conform to the requirements.
- MSS SP-67 Butterfly Valves.
- ISO 5211 Actuator Mounting
- USCG Category "A" Title 46, CFR, Part 56

# ENGINEERING

## DIMENSIONS

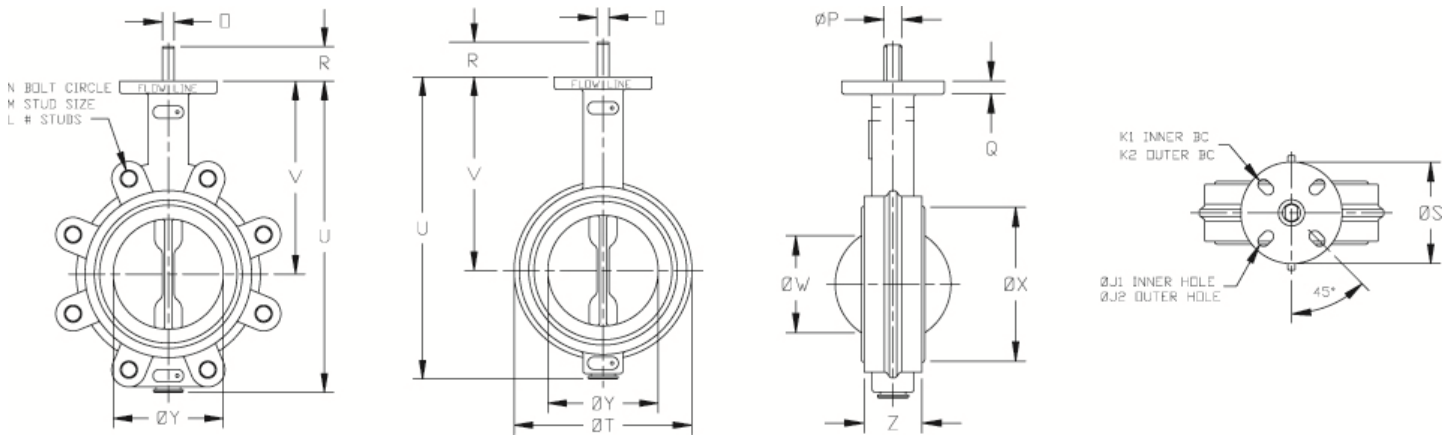

Valve Size	Z	Y	X	W	V	U	S	R	Q	P	O	Lug Drilling			Top Plate Drilling				Weight (lb)	
												N	M	L	K1	K2	#holes	J1		J2
2	1.66	2.10	3.00	1.24	5.62	8.44	4.00	0.827	.44	0.551	0.551	4.75	5/8-11	4	2.76	3.25	4	.39	.41	8
2.5	1.76	2.47	3.50	1.82	6.12	9.19	4.00	0.827	.44	0.551	0.551	5.50	5/8-11	4	2.76	3.25	4	.39	.41	10
3	1.78	3.04	4.09	2.54	6.38	9.69	4.00	0.827	.44	0.551	0.551	6.00	5/8-11	4	2.76	3.25	4	.39	.41	11
4	2.05	4.00	5.31	5.54	7.12	11.00	4.00	0.827	.44	0.551	0.551	7.50	5/8-11	8	2.76	3.25	4	.39	.41	17
5	2.14	4.80	6.26	4.36	7.75	12.12	4.00	1.63	.44	0.670	0.670	8.50	3/4-10	8	2.76	3.25	4	.39	.41	23
6	2.19	6.07	7.42	5.72	8.25	13.25	4.00	1.063	.44	0.670	0.670	9.50	3/4-10	8	2.76	3.25	4	.39	.41	29
8	2.39	7.91	9.38	7.60	9.44	15.56	6.00	1.063	.56	0.866	0.866	11.75	3/4-10	8	4.02	5.00	4	.53	.53	44
10	2.58	9.80	11.51	9.51	11.28	18.69	6.00	1.063	.56	0.866	0.866	14.25	7/8-9	12	4.02	5.00	4	.53	.53	66
12	3.03	11.81	13.55	11.48	12.19	21.69	6.00	1.063	.56	0.866	0.866	17.00	7/8-9	12	4.02	5.00	4	.53	.53	99

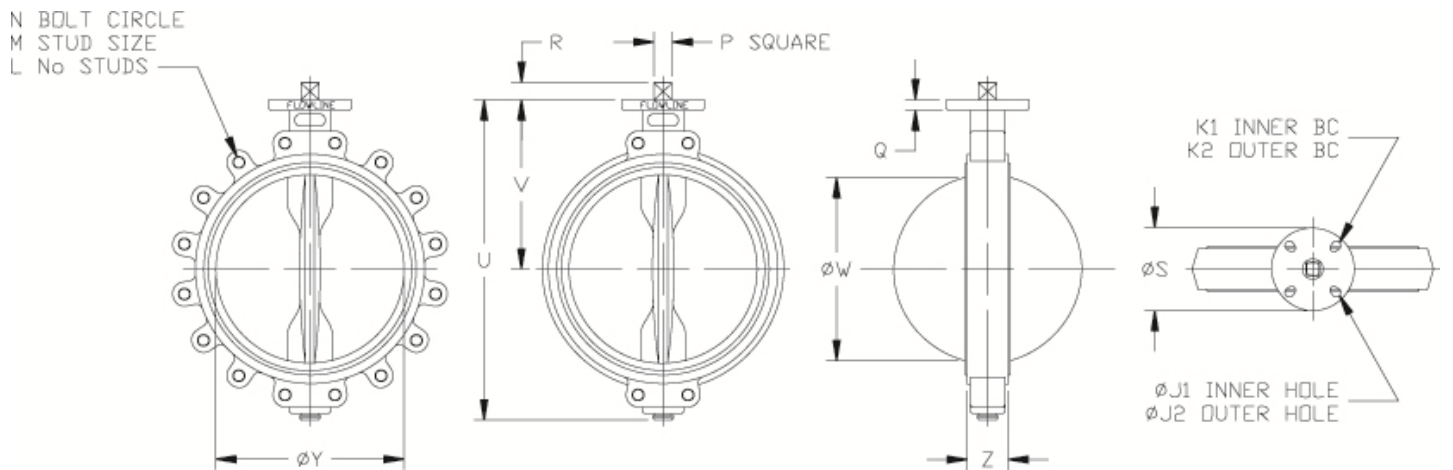

Valve Size	Z	Y	W	V	U	S	R	Q	P	Lug Drilling			Top Plate Drilling				Weight (lb)	
										N	M	L	K1	K2	#holes	J1		J2
14	2.87	13.12	12.26	13.04	23.18	6.87	1.45	.86	1.06	18.75	1-8 UNC	4	4.92	5.51	4	.625	.75	120
16	3.37	15.62	14.39	14.01	26.52	6.87	1.45	.86	1.06	21.25	1-8 UNC	4	4.92	5.51	4	.625	.75	165
18	4.18	17.56	16.41	15.03	28.18	6.87	1.45	.98	1.06	22.75	1-1/8-7-UNC	4	4.92	5.51	4	.625	.75	210
20	5.18	19.56	18.67	16.06	30.25	6.87	1.92	.98	1.41	25.00	1-1/8-7-UNC	4	-	5.51	4	6.25	.75	250
24	6.02	23.56	22.84	19.12	35.87	6.87	1.92	.98	1.41	29.50	1-1/8-7-UNC	4	-	5.51	4	-	.75	400

# SPECIFICATIONS

## HOW TO ORDER

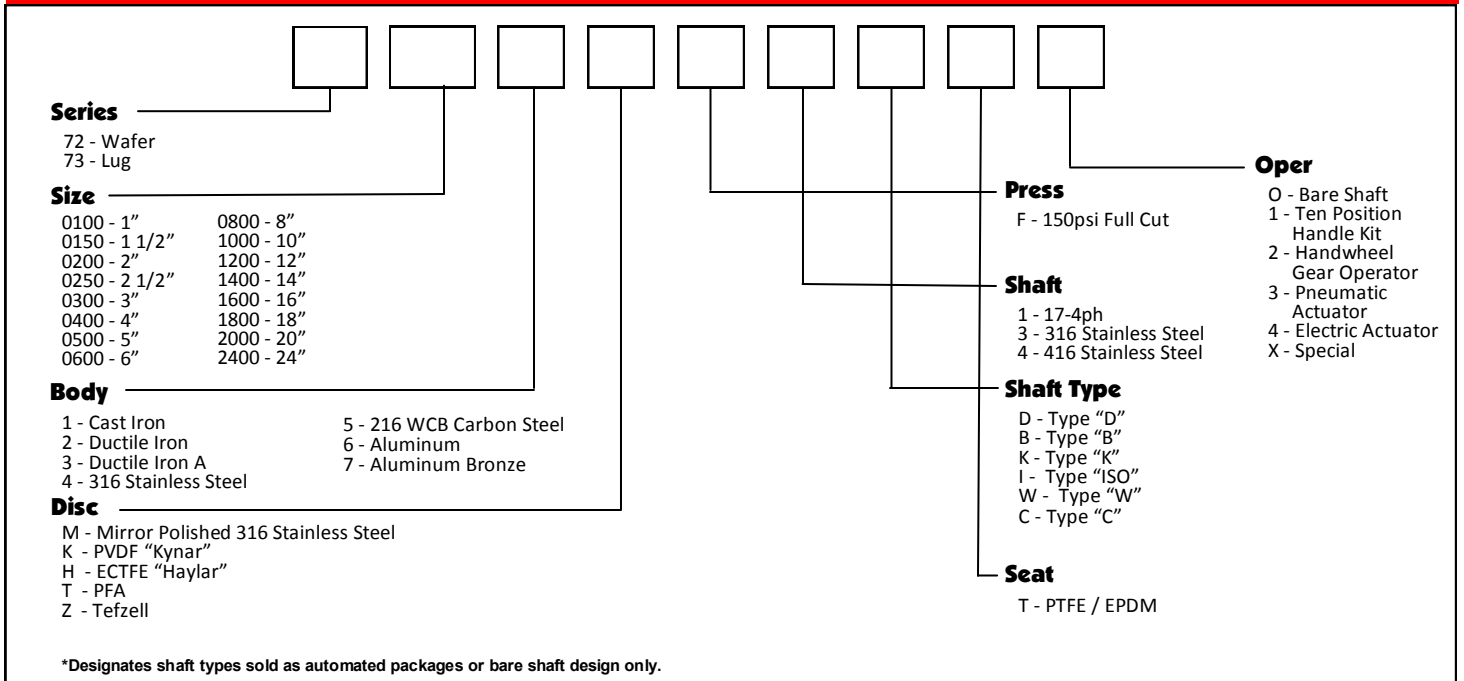

## Recommended Specifications

- Polyester coated wafer or lug bodies provided extended necks for insulation and be able to install between ANSI 125/150 flanges.
- Streamlined disc design with no pins or screws in the flow path and designed for high Cv and lower pressure drop.
- Upper and lower shaft design to utilize triple shaft seals as standard.
- Blow out proof design utilizing a Double D drive for a positive disc/shaft connection.
- Pressure responsive 360° sealing design will use constant pressure between machined radius on disc and flatted area of the seat.
- Valve to be Flow Line Series 72 wafer or Flow Line Series 73 lug design.

## Materials of Construction 1"-24"

### Body

- Cast Iron ASTM A-126 Class B
- Ductile Iron ASTM A-536 (65-45-12)
- 316 Stainless Steel ASTM A-351 (CF8M)
- Carbon Steel ASTM A-216 WCB

### Disc

- Mirror Polish 316 Stainless Steel ASTM A-351 (CF8M)
- Kynar Coated 316 Stainless Steel
- Haylar Coated 316 Stainless Steel
- PFA Coated 316 Stainless Steel
- Tefzell Coated 316 Stainless Steel

### Stem

- 316 Stainless Steel ASTM A-276  
Type 316
- 416 Stainless Steel ASTM A-582  
Type 416

### Seat

- PTFE / EPDM FDA Food Grade 30° +257°
- PTFE / Viton® FDA Food Grade 0° +375°
- PTFE / Buna N FDA 0° +180°

## Components

Qty	Description	Qty	Description
1	Body	2	Shaft Retainers
1	Disc	1	Bearing Retainers
1	Upper Shaft	1	Environmental Retainer
1	Lower Shaft	2	Secondary Shaft Seals
1	Seat	1	Thrust Bearing
		1	Inboard Bearing

# FEATURES

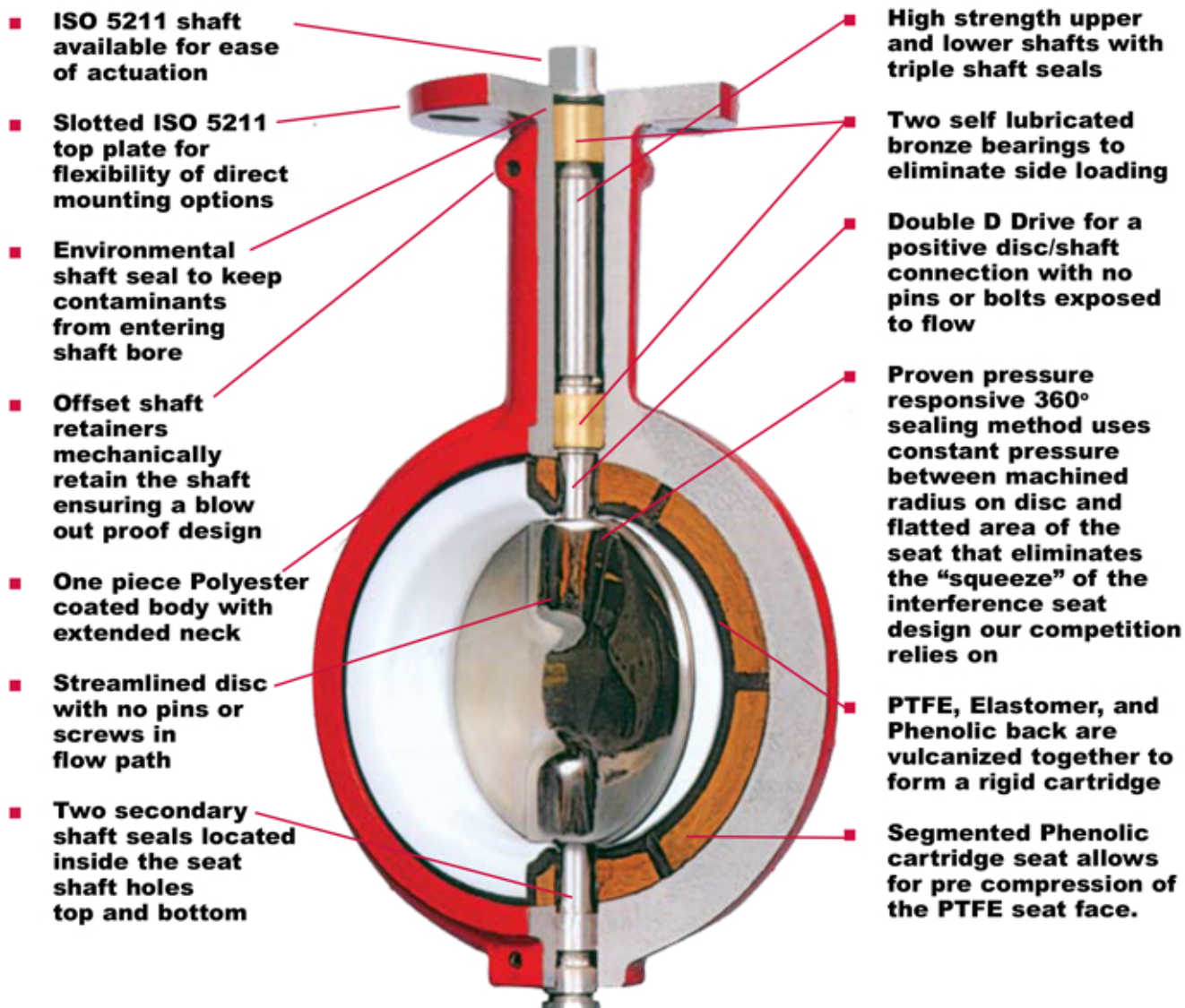

- ISO 5211 shaft available for ease of actuation
- Slotted ISO 5211 top plate for flexibility of direct mounting options
- Environmental shaft seal to keep contaminants from entering shaft bore
- Offset shaft retainers mechanically retain the shaft ensuring a blow out proof design
- One piece Polyester coated body with extended neck
- Streamlined disc with no pins or screws in flow path
- Two secondary shaft seals located inside the seat shaft holes top and bottom

- High strength upper and lower shafts with triple shaft seals
- Two self lubricated bronze bearings to eliminate side loading
- Double D Drive for a positive disc/shaft connection with no pins or bolts exposed to flow
- Proven pressure responsive 360° sealing method uses constant pressure between machined radius on disc and flattened area of the seat that eliminates the "squeeze" of the interference seat design our competition relies on
- PTFE, Elastomer, and Phenolic back are vulcanized together to form a rigid cartridge
- Segmented Phenolic cartridge seat allows for pre compression of the PTFE seat face.

The **Series 72 wafer** style and **Series 73 lug** style are heavy duty PTFE cartridge seated butterfly valves. All Series 72 and 73 valves utilize a mirror polished 316 stainless steel disc. Kynar and Haylar coated 316 stainless steel disc are used in applications requiring the line media not to come into contact with organic or metallic materials. Series 72 and 73 PTFE lined valves are rated to 150 psi. All Series 72/73 PTFE seated valves are vacuum rated to 29.916" of Mercury Gauge (100 microns).

## COATINGS

Flow Line Series 72 and 73 butterfly valve bodies are Polyester coated as standard. Polyester is a significant upgrade to paint or two part epoxy coatings. Our standard Polyester coating offers outstanding protection against abrasion and corrosion. The Flow Line Polyester coating is not affected by outdoor exposure and maintains excellent resistance to UV rays.

TEST	RESULT
Salty Fog Test	No change in excess of 2000 hours
Outdoor Weathering (UV Rays)	No noticeable change in excess of 12 months
50% Sulfuric Acid Test	No change for 48 hours

# INSTALLATION, MAINTENANCE AND ASSEMBLY

## Handle Kit



The Flow Line Handle Kit is designed for manual on/off and throttling service for quarter turn, resilient seated butterfly valves ranging from 2" - 12". The Polyester coated ductile iron handle kit includes the handle assembly with a locking lever and bolt on plate notched at 10 degree increments. The notched plate also includes on/off stops to prevent over travel of the handle and can be used with a padlock as standard. Other available options include an Infinite Throttling Handle Kit, Memory Stop and a 2" Square Nut.

## Handwheel Gear Operator



available options include a Chainwheel Kit, Padlock Kit and a 2" Square Nut.

The Flow Line Handwheel Gear Operator is designed for manual on/off and throttling service for quarter turn butterfly valves ranging from 2" - 12". The handwheel gear operator is constructed with a heavy duty, Polyester coated ductile iron housing, is completely self lubricated and weatherproof. Along with the gear operator, it also includes a valve position indicator, ductile iron handwheel and mechanical travel stops for field adjustment. Other

## Actuation



Series 21 spring return actuators are available throughout the size range.



Series 50 solenoid valves are available in 1/8", 1/4", and 1/2"NPT.



Series 52 and 53 limit switches provide local and remote valve position.



Series 55 and 56 positioners are available with either a 3-15 psi or 4-20 MADC signal.

## Installation

To install, simply close the valve, position between the flanges and assemble the valve to the flanges with studs or cap screws. Do not use flange gaskets. Flow Line Series 72 and 73 butterfly valves can be installed with the disc closed. Before hand tightening the flange bolts, fully open the disc to ensure disc O.D. clearance with pipe I.D. Hand tighten the flange bolts and close the valve to check for valve disc and pipe clearance. If contact is made, reposition as necessary and tighten all flange bolts to proper torque specification.

## Maintenance and Repair

No regular maintenance or lubrication is required. Factory assembly procedures provide adequate lubrication for the life of the valve. To replace any component, remove valve from the line by fully closing valve disc. Spread flanges, remove all bolts then remove valve from line.

## Testing

All Flow Line Series 72 and 73 butterfly valves are bi-directionally tested to 130 percent of rated working pressure. Test certification is available upon request at time of order.

## Flanges

ANSI 125/150 cast iron, steel, raised face, flat faced weld neck, slip on and threaded flanges are suitable for use with Flow Line butterfly valves. Please contact the factory for proposed installation with plastic flanges.

## Warranty

All products manufactured by Flow Line Valve and Controls are warranted against defects in material and workmanship for a period of 1 year from date of invoice.

All statements, technical information and recommendations in the bulletin are for general use only. Flow Line Valve and Controls is not responsible for suitability or compatibility of these products in relation to system requirements. Consult Flow Line Valve and Controls distributors or factory for the specific requirements and material selection for your intended application. Flow Line Valve and Controls reserves the right to change or modify product design or product without prior notice. Flow Line Valve and Controls is not responsible for editorial or pictorial errors within this literature.

# Flow Line

110 Main Project Rd. Schriever, LA 70395

Phone (985) 414-6000 Fax (985)

414-6072 Toll 800-815-9226

[www.flowlinevalves.com](http://www.flowlinevalves.com)

Doc#FLBVT1

© Flow Line