

VALVE SIZE	RATIO	A	B	C	D	E	F	G	H	J	MOUNTING PATTERN		DRIVE DIA	BORE A/F	WGT LBS
											BC	THREAD			
2" - 4" 5" - 6"	24:1	.63	7.00	.19	.625	5.12	2.31	4.25	9.12	6.0	3.25	4 x 3/8-16 x .75 DP	.625 .838	.375 .500	7.5
8" 10" 12"	30:1	1.15	10.06	.19	.750	7.00	3.00	6.12	13.12	12.0	5.00	4 x 1/2-13 x 1.00 DP	.838 .963 1.338	.500 .625 .750	23.5

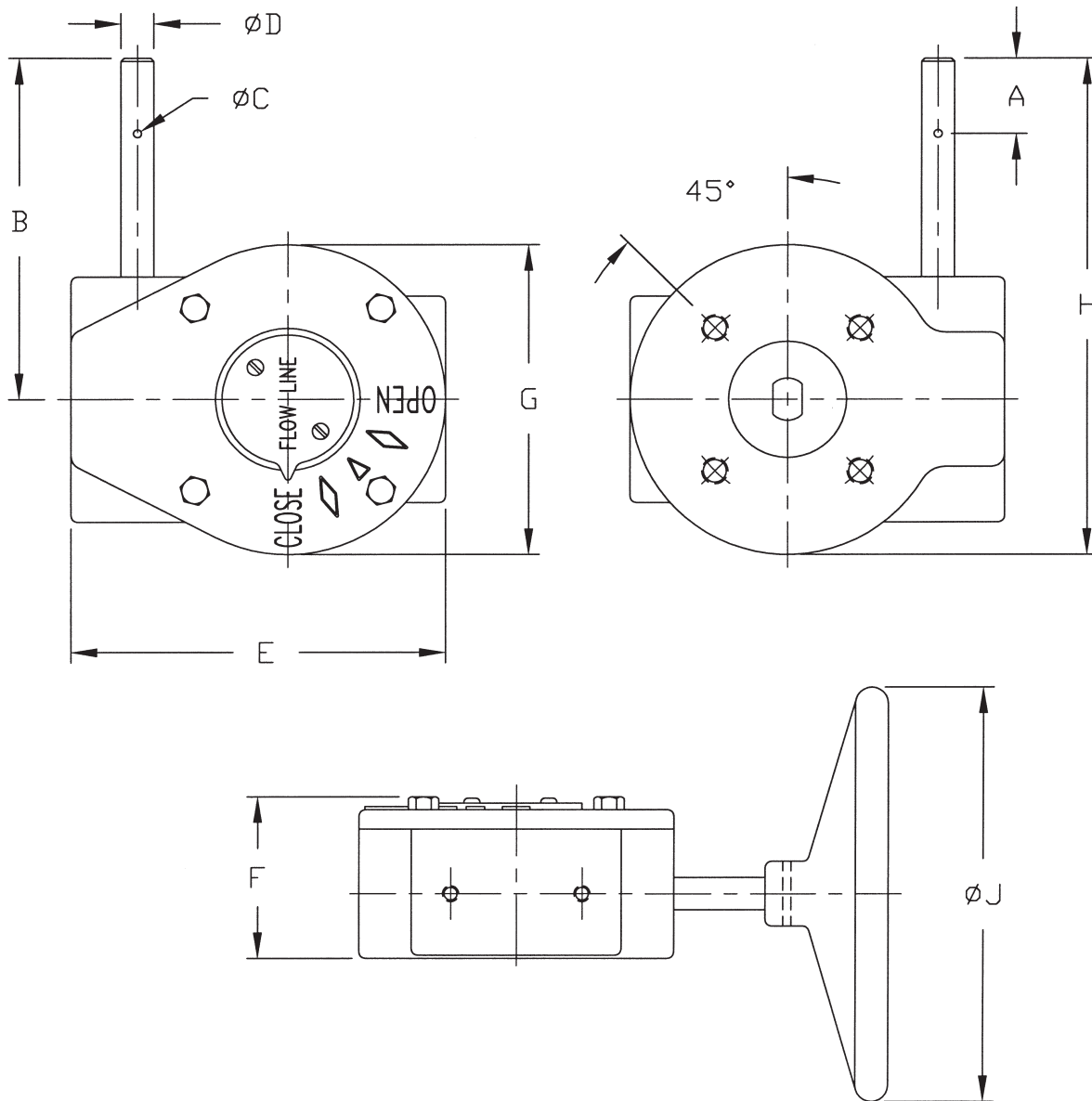

CUSTOMER/PROJECT	DIMENSIONAL DATA SHEET GEAR ACTUATOR SERIES 15	PART NO.	
INQ./PO NO.		DRAWING NO. 5-001	REV A
ORDER NO.		DATE 1/02	
CERTIFIED BY		DATE	