

VALVE SIZE	Z	Y	X	W	V	U	S	R	Q	P	O	LUG DRILLING			TOP PLATE DRILLING				WGT (LB)	
												N	M	L	K1	K2	#holes	J1		J2
2	1.74	2.25	2.65	1.47	5.62	8.44	4.00	1.00	.44	.625	.375	4.75	5/8-11	4	2.76	3.25	4	.39	.41	8
2-1/2	1.86	2.81	3.15	2.14	6.12	9.19	4.00	1.00	.44	.625	.375	5.50	5/8-11	4	2.76	3.25	4	.39	.41	10
3	1.86	3.31	3.78	2.74	6.38	9.69	4.00	1.00	.44	.625	.375	6.00	5/8-11	4	2.76	3.25	4	.39	.41	11
4	2.11	4.19	4.78	3.60	7.12	11.00	4.00	1.00	.44	.625	.375	7.50	5/8-11	8	2.76	3.25	4	.39	.41	17
5	2.24	5.06	5.84	4.58	7.75	12.12	4.00	1.25	.44	.838	.500	8.50	3/4-10	8	2.76	3.25	4	.39	.41	23
6	2.24	6.06	7.03	5.62	8.25	13.25	4.00	1.25	.44	.838	.500	9.50	3/4-10	8	2.76	3.25	4	.39	.41	29
8	2.54	7.94	8.96	7.43	9.44	15.56	4.00	1.38	.56	.838	.500	11.75	3/4-10	8	4.02	5.00	4	.53	.53	44
10	2.74	10.00	11.09	9.38	11.25	18.69	4.00	1.38	.56	.963	.625	14.25	7/8-9	12	4.02	5.00	4	.53	.53	66
12	3.24	11.94	13.09	11.35	12.19	21.69	4.00	1.38	.56	1.338	.750	17.00	7/8-9	12	4.02	5.00	4	.53	.53	99

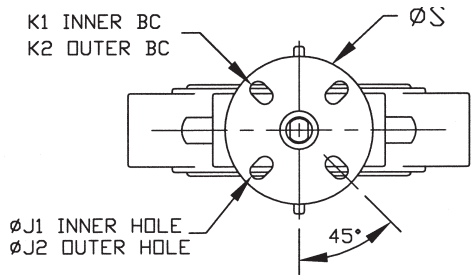

4	STEM		
3	DISC		
2	SEAT		
1	BODY		
ITEM	DESCRIPTION	MATERIAL	REMARKS

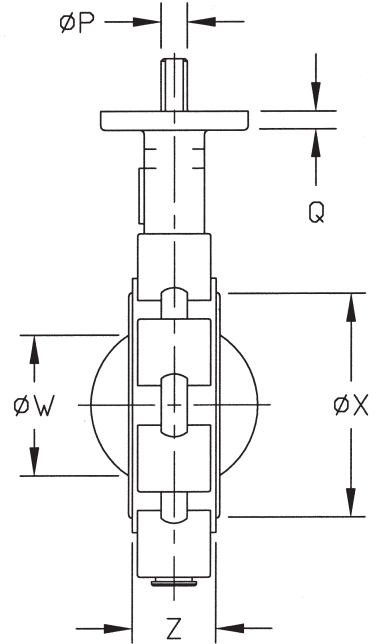
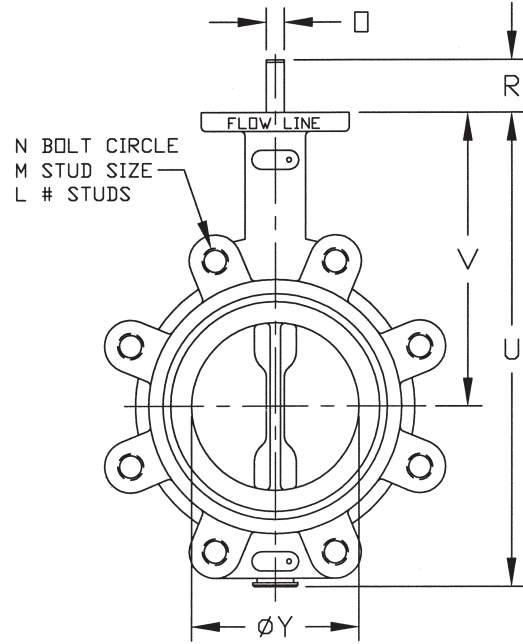

VALVE SIZE	FLANGE DRILLING	DIMENSIONAL DATA SHEET		PART NO.	
PRESSURE RATING		<b>BUTTERFLY VALVE</b> <b>SERIES 71</b> <b>SIZES 2"-12"</b>		DRAWING NO.	REV
CUSTOMER/PROJECT				71-001	A
INQ./PO NO.				DATE	
ORDER NO.				1/02	
CERTIFIED BY	DATE				